

# Eclipse 2

Control board for swing gates. **REV. 3**

**ELCA**  
 Via Malintoppi, 32  
 63025 FERMO (AP) ITALY  
 Tel/Fax: (0039) 0734 605080  
 Web: www.elcasnc.com  
 E-Mail: elcasnc@tin.it

**!** FOLLOW THIS INSTRUCTIONS CAREFULLY **CE**

This manual contains important instructions for installation and use of this control board mod. ECLIPSE2. Don't install before reading this manual, the security of the product depends on a correct installation. The producing company declines any responsibility in case of a not correct instalment or improper use. This product has been created by keeping the strictest safety norms following EC directives : CEE 73/23, CEE 89/336, CEE 93/68, CEE 89/106, CEE 89/392.

**This manual has to stay with the equipment at all time, must not remove!**

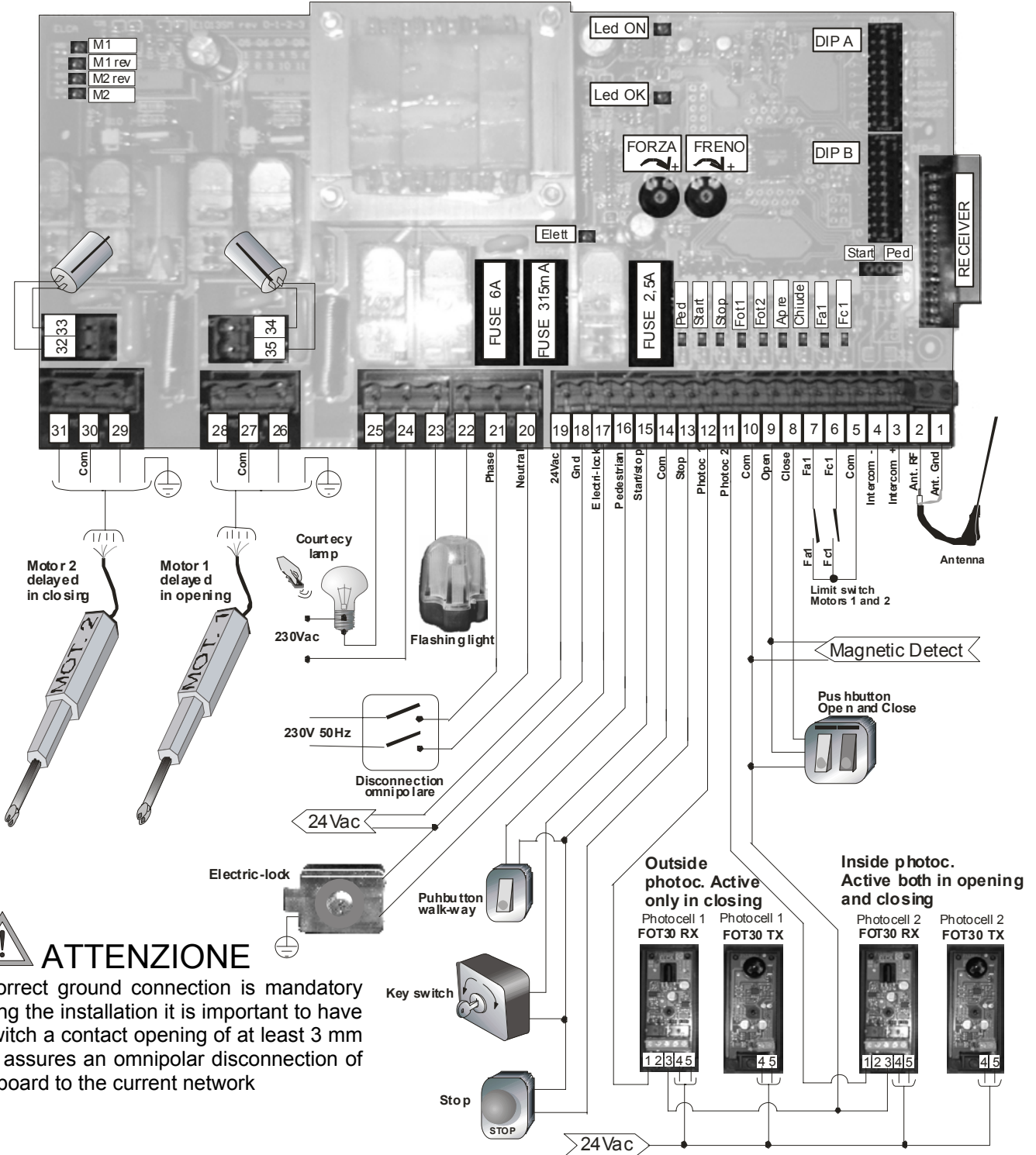

**!** **ATTENZIONE**

A correct ground connection is mandatory during the installation it is important to have a switch a contact opening of at least 3 mm that assures an omnipolar disconnection of the board to the current network

**FOR SAFETY REASON A SAFETY DEVICE MUST BE USE WHEN USING THIS REMOTE CONTROL !!!**

**TERMINALS CONNECTIONS :**

<b>1-2</b>	Antenna, terminal n°2 = RF	<b>15-14</b>	“Start/Stop” push button (n.o. contact)
<b>3-4</b>	Input from intercom 12Vac see <T>	<b>16-14</b>	SS2 push button motor n 2 command
<b>5-6</b>	Closing limit switch (n.c. contact) see <D>	<b>17-18</b>	Electric - lock 12vac-15w
<b>7-5</b>	Opening limit switch (n.c. contact) see <D>	<b>18-19</b>	24Vac output (max 3 pairs of photocell)
<b>8-5</b>	“open” push button (n.o. contact) or Magnetic Detect	<b>20-21</b>	<b>POWER SUPPLY 230V-50Hz</b>
<b>9-10</b>	“close” push button (n.o contact)	<b>22-23</b>	<b>Flashing light 230V -25w</b>
<b>11-10</b>	Photocell n 2 (n.c. contact) or rubber see logic <H>	<b>24-25</b>	<b>Courtesy light contact ( free voltage)</b>
<b>12-10</b>	Photocell n 1 (n.c. contact)	<b>26-27-28</b>	<b>Motor n 1 (terminal N.27 = com.)</b>
<b>13-14</b>	“Stop” push button (n.c. contact)	<b>29-30-31</b>	<b>Motor n.2 (terminal. N.30 = com.)</b>

**LED FUNCTIONS**

<b>ON</b>	Normally ON POWER ON BOARD
<b>OK</b>	<ul style="list-style-type: none"> <li>▪ 1 flashing when a radio code is received and recognized</li> </ul> During programming <ul style="list-style-type: none"> <li>▪ 1 flashing when a code is memorized</li> <li>▪ <b>3 flashing = error</b>, the code received is already in memory or memory is full</li> <li>▪ ON, during motor timing programming</li> <li>▪ ON, during pause timing programming</li> <li>▪ ON, during RESET</li> <li>▪ Flashing when the RESET has been execute</li> </ul>
<b>M1</b>	ON, when motor n 1 is activated
<b>M1rev</b>	Show the direction of motor n 1
<b>M2rev</b>	Show the direction of motor n 2

<b>M2</b>	ON, when motor n 2 is activated
<b>Elett</b>	ON, when electric-lock is activated
<b>Ped</b>	ON, when SS2 button is pushed
<b>Start</b>	ON, when START button is pushed
<b>Stop</b>	Normally ON it turns OFF when STOP button is pushed
<b>Fot1</b>	Normally ON it turns OFF when the photocell n 1 ray is interrupt
<b>Fot2</b>	Normally ON it turns OFF when the photocell n 2 ray is interrupt
<b>Apré</b>	ON, when OPEN button is pushed
<b>Chiude</b>	ON, when CLOSE button is pushed
<b>Fa1</b>	Normally ON it turns OFF when the open limit switch is activated
<b>Fc1</b>	Normally ON it turns OFF when the close limit switch is activated

**DIPS SWITCH:**

DIP SWITCH “A”		DIP SWITCH “B”	
<b>A1</b>	Pre-flashing -- L --	<b>B1</b>	Electric-lock -- N --
<b>A2</b>	Walk-way 45° -- M --	<b>B2</b>	Motor phase reverse – G --
<b>A3</b>	Logic 0 -- H --	<b>B3</b>	In ON position = motor delay erased
<b>A4</b>	Logic 1 -- H --	<b>B4</b>	In ON position = slow-down erased
<b>A5</b>	Pause time activated	<b>B5</b>	In ON position = locking for wind – P -
<b>A6</b>	Pause time program – E --	<b>B6</b>	Open gate signal – Q --
<b>A7</b>	M1 timing program – B --	<b>B7</b>	Courtesy lamp = 2 seconds – R --
<b>A8</b>	M2 timing program – B --	<b>B8</b>	Courtesy lamp code program – A4 --
<b>A9</b>	Start code program – A1 --	<b>B9</b>	Soft motor Start – S --
<b>A10</b>	ERASE – I --	<b>B10</b>	Walk-way code program – A7 --

**YOU CAN USE WITHOUT PROGRAMMING..... ! -**

The control board is supplied with a BASI PROGRAM that give you the following functions :

- Motors timing : **20 seconds** –slow-down excluded
- Pause time : **30 seconds**
- Delay time : **5 seconds in closing and 2 seconds in opening**
- Courtesy lamp time : **3 minutes**
- Radio code in memory: channel n 1 ASTER with dips **1,3,5,7,9 = ON = BASIC CODE.**

>>>> AT ANY TIME YOU CAN FETCH THE BASIC PROGRAM BY THE RESET FUNCTION <<<<

**RESET**

- Turn OFF the power.
- Set the dips **A7, A8, A10** in ON position
- Turn ON the power, the led OK goes ON, then start to flashing, the reset is finish
- Set the dips **A7, A8, A10** in OFF position, the led OK goes off

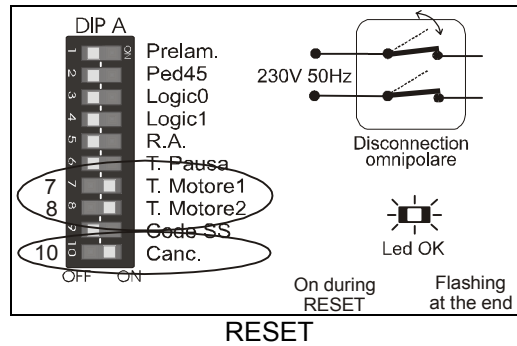

- **ATTENTION !!!** – during normal function the dips: **A6, A7, A8, A9, A10, B2, B8, B10**, MUST BE IN OFF POSITION.

**<A> CODE RADIO PROGRAMMING.**

- as soon the first code is memorized the "basic code" will be erased
- max code in memory : 160 standard code or 53 rolling code
- if the first code memorized is a rolling code then the board accept only rolling code, to accept again the standard code, RESET must be done

<p><b>Code Start/Stop</b></p> <p>A1. set the <b>DIP A9</b> in ON position</p> <p>A2. send a code with transmitter ( about 50 cm far ) the OK led give you a confirm with 1 flashing, if the led make 3 flashing that means that the code is already in memory or the memory is full</p> <p>A3. set the <b>DIP A9</b> in OFF position</p>	
<p><b>Code courtesy lamp</b></p> <p>A4. set the <b>DIP B8</b> in ON position</p> <p>A5. send a code with transmitter as step A2</p> <p>A6. set the <b>DIP B8</b> in OFF position</p>	
<p><b>Code walk-way SS2</b></p> <p>A7. set the <b>DIP B10</b> in ON position</p> <p>A8. send a code with transmitter as step A2</p> <p>A9. set the <b>DIP B10</b> in OFF position</p>	

### Code Stop

- A10. set the **DIP A9** in ON position and open the contact between terminals n **13-14**.
- A11. send a code with transmitter as step A2
- A12. set the dip **A9** in OFF position and close the contact on terminals n **13-14**.

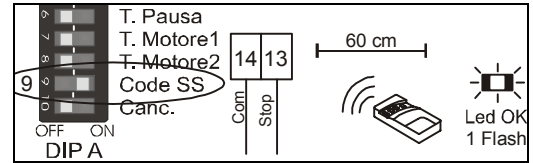

- A13. **Code Open:** Set the **DIP A9** in ON position and close the contact between terminals n **8 – 5**. Send a code with transmitter. Set the dip **A9** in OFF position and open the contact on terminals n **8 - 5**.
- A14. **Code Close:** Set the **DIP A9** in ON position and close the contact between terminals n **9 – 10**. Send a code with transmitter. Set the dip **A9** in OFF position and open the contact on terminals n **9 - 10**.

!!!! TO ERASE A CODE SEE STEP - I -.

### <B> MOTORS TIMING PROGRAMMING ,WITH SLOW-DOWN

- set and leave the **DIP B4** in OFF position.
- set the trimmer **Forza** to "+".
- set the trimmer **Freno** to mid range.



**ATTENTION:** for a correct function it is necessary that the gate have a physical stop in opening and in closing



**ATTENTION:** if YOU HAVE ONLY ONE MOTOR YOU MUST CONNECT AS MOTOR N 2 (terminals n 29-30-31 ) AND YOU MUST SET AND LEAVE THE **DIP B3** in ON.position.

#### - Time motor n°2 -

<p>B1. by hand close swing n 2. Turn OFF the power. Turn ON the power</p>	
<p>B2. set the <b>DIP A8</b> in ON position, the led OK goes on.</p>	
<p>B3. send a command with transmitter or by start push button, if the motor does not move in opening the phase inversion &lt;G&gt; must be done.</p>	
<p>B4. when slowing down is required send a second command at this point the motor move at the speed set by the trimmer FRENO.</p>	

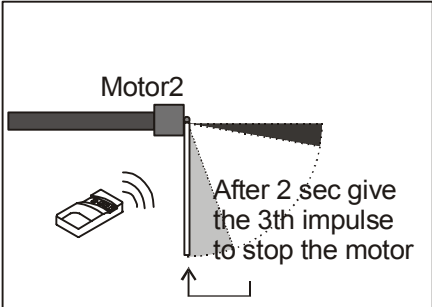
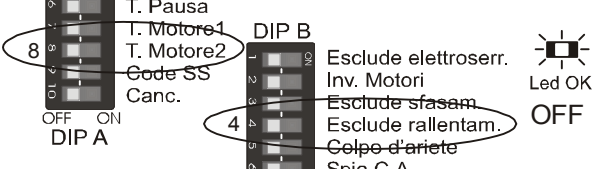
<p>B5. After 2 seconds that the gate is completely opened send a third command for stopping.</p>	
<p>B6. repeat steps B3, B4, B5 for closing time programming.</p>	
<p>B7. set the <b>DIP A8</b> in <b>OFF</b> position ,the <b>led OK</b> goes off.</p>	

**- Time motor n 1 -**

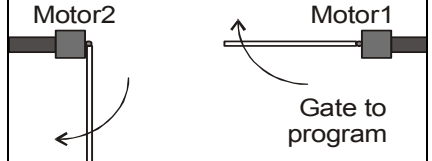
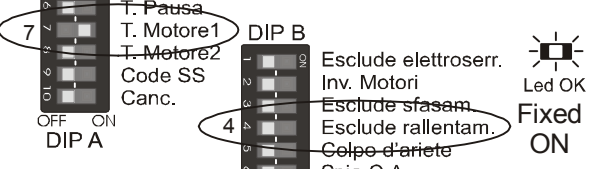
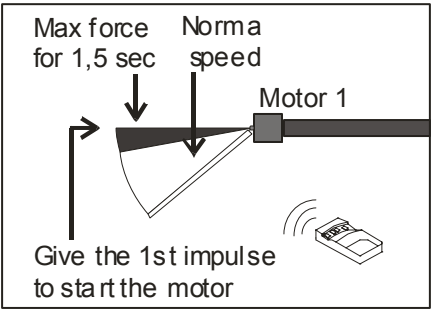
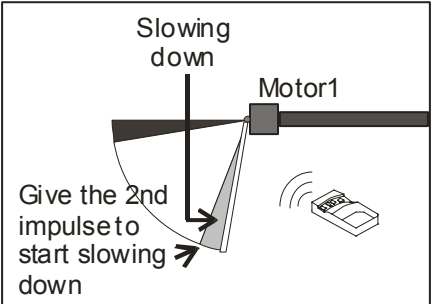
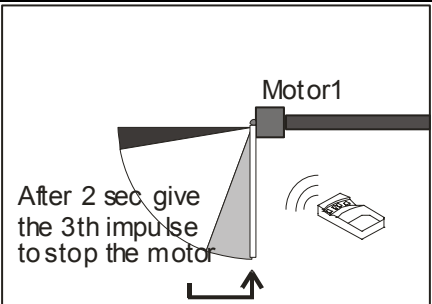
<p>B8. by hand close the swing n 1, leave swing n 2 open Turn OFF the power. Turn ON the power.</p>	
<p>B9. set the <b>DIP A7</b> in <b>ON</b> position ,the <b>led OK</b> goes on.</p>	
<p>B10. send a command with transmitter or by start push button, if the motor does not move in opening the phase inversion <b>&lt;G&gt;</b> <b>must be done</b></p>	
<p>B11. when slowing down is required send a second command at this point the motor move at the speed set by the trimmer FRENO.</p>	
<p>B12. after 2 seconds that the gate is completely opened send a third command for stopping.</p>	
<p>B13. repeat steps B10, B11, B12 for closing time programming.</p>	

<p>B14. set the <b>DIP A7</b> in <b>OFF</b> position the <b>led OK</b> goes off.</p>	
--	--

NOTE : you can make several movement in opening and in closing, only the last will be memorized !!!!.

**<C>MOTORS TIME PROGRAMMING WITHOUT SLOWING DOWN.**

- set and leave the **DIP B4** in **ON** position.
- set the trimmer **Forza** to +” .

**ATTENTION:** for a correct function it is necessary that the gate have a physical stop in opening and in closing.

**ATTENTION:** if you have only one motor you have to connect has motor n 2 ,terminals n 29-30-31,and you must set the **DIP B3** in **ON** position.

**- time Motor n°2 -**

<p>C1.place the gate n 2 in closing position Turn OFF the power. Turn ON the power.</p>	
<p>C2.set the <b>DIP A8</b> in <b>ON</b> position, the <b>led OK</b> goes on</p>	
<p>C3.send a command with transmitter or by start push button, if the motor does not move in opening the phase inversion <b>&lt;G&gt;</b> must be done.</p>	
<p>C4.after 2 seconds that the gate is completely opened send a second command for stopping.</p>	
<p>C5.repeat steps C3, C4 for closing time programming</p>	
<p>C6.set the <b>DIP A8</b> in <b>OFF</b> position, the <b>led OK</b> goes off.</p>	

**- time Motor n°1 -**

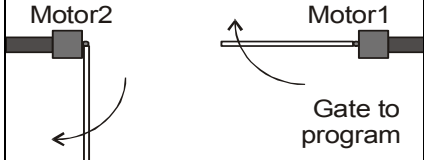
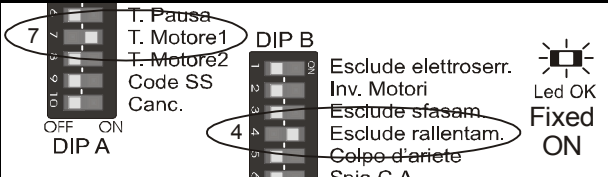
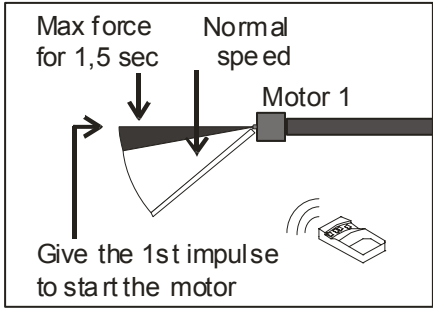
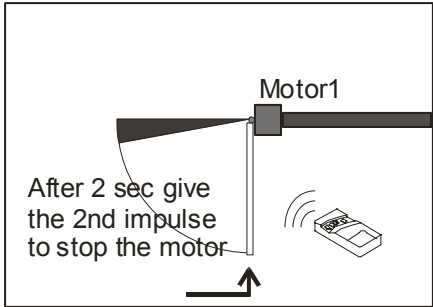
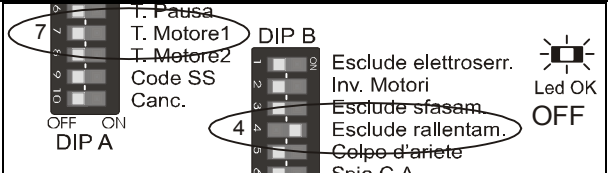
<p>C7. place the gate n 2 open and the gate n 1 to close position. Turn OFF the power. Turn ON the power</p>	
<p>C8. set the <b>DIP A7</b> in <b>ON</b> position, the <b>led OK</b> goes on.</p>	
<p>C9. send a command with transmitter or by start push button, if the motor does not move in opening the phase inversion <b>&lt;G&gt;</b> must be done.</p>	
<p>C10. after 2 seconds that the gate is completely opened send a second command for stopping.</p>	
<p>C11. repeat steps C9, C10 for closing time programming.</p>	
<p>C12. set the <b>DIP A7</b> in <b>OFF</b> position, the <b>led OK</b> goes off.</p>	

**<E> PAUSE TIME PROGRAMMING**

NOTE : to enable pause time set and leave the **DIP A5** in ON position.



ATTENTION: before start with pause time program check that the **DIP B3** is in **OFF** position.

- E1. set the **DIP A6** in ON position, the **led OK** goes on, leaving for as long as pause is required ( from 1 second up 20 minutes )
- E2. set the **DIP A6** in OFF position the **led OK** goes off.

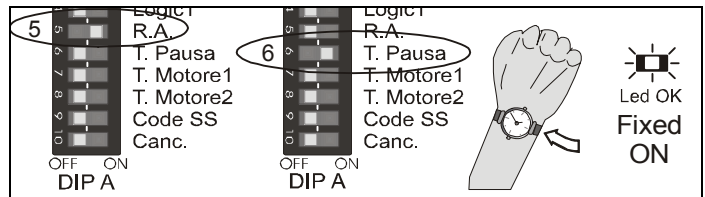

E1

## <F> CHANGE DELAY CLOSING TIME

- F1. set the **DIP B3** in **ON**. position
- F2. set the **DIP A6** in **ON** position, the **led OK** goes on, leaving for the time required, then set it in OFF position.
- F3. set the **DIP B3**.in OFF position

NOTE: if the dip **B3** is leave in ON position the time delay is = 0 second that mean booth motor start in closing at the same time

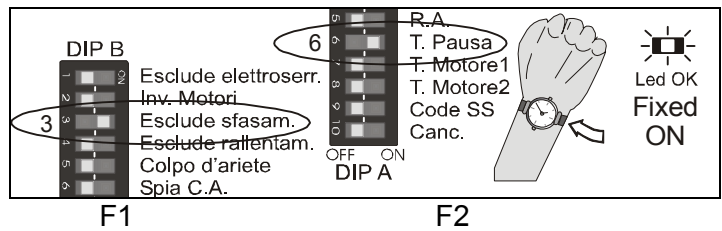

## <G> REVERSE MOTOR PHASE

- this function automatically change the phase motor, in this way does not need to change the motor wire connections

### Reverse phase motor n 1

- G1.set the **DIP B2**.in ON position
- G2.set the **DIP A7** in ON position, the **led OK** make a flash to indicate that the reverse is done
- G3.set the dips **A7** and **B2** in OFF position, the **led OK** goes off.

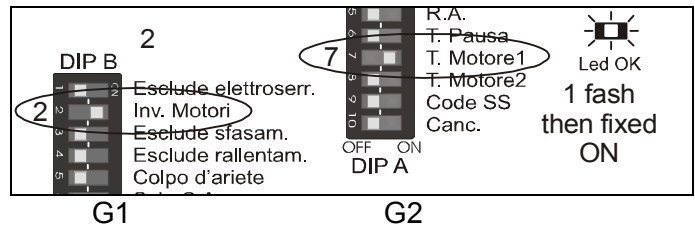

### Riverse phase motor n 2

- G4.set the **DIP B2**.in ON position
- G5.set the dip **A8** in ON position, the **led OK** make a flash to indicate that the reverse is done.
- G6.set the dips **A8** and **B2** in OFF position, the **led OK** goes off.

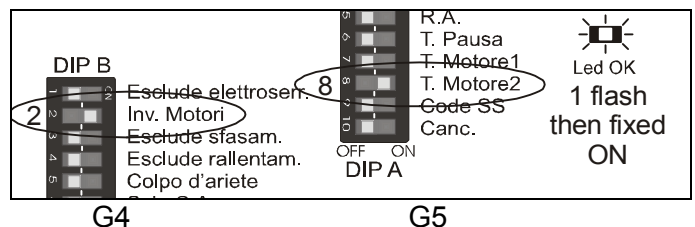

## <H> LOGIC

--- set and leave the dips **A3** and **A4** as you need.

DIP A	Logic
<p>DIP A Prelam. Ped45 Logic0 Logic1 R.A. T. Pausa</p>	<p><b>Logic step by step</b></p> <p>The first command open, the second make a stop, the third start closing and so on.....</p>
<p>DIP A Prelam. Ped45 Logic0 Logic1 R.A. T. Pausa</p>	<p><b>No step by step logic</b></p> <p>One command open, during the open other command does not make effect, during the closure one command invert to open.</p>
<p>DIP A Prelam. Ped45 Logic0 Logic1 R.A. T. Pausa</p>	<p><b>Immediate close after cross photocell n1 and n 2.</b></p>

	<p><b>No step by step logic for pneumatic bar</b></p> <p>If on terminals n 10-11 you connect a pneumatic bar, when the bar is pressed the gate reverse the movement for 1,5 second then stop.</p>
--	---

## <I> RADIO CODE ERASING

### - erasing all code.

1. if you make the **RESET** function, all code are erasing and the **BASIC CODE** come back in memory.

<p><b>Erasing Start/Stop code</b></p> <ol style="list-style-type: none"> <li>12. set the <b>DIP A9</b> in <b>ON</b> position</li> <li>13. set the <b>DIP A10</b> in <b>ON</b> position, the <b>Led OK</b> make a flash.</li> <li>14. set the dips <b>A9</b> and <b>A10</b> in <b>OFF</b> position</li> </ol>	
<p><b>Erasing courtesy lamp code</b></p> <ol style="list-style-type: none"> <li>15. set the <b>DIP B8</b> in <b>ON</b> position</li> <li>16. set the <b>DIP A10</b> in <b>ON</b> position, the <b>Led OK</b> make a flash</li> <li>17. set the dips <b>DIP B8</b> and <b>A10</b> in <b>OFF</b> position</li> </ol>	
<p><b>Erasing walk-way code SS2</b></p> <ol style="list-style-type: none"> <li>18. set the <b>DIP B10</b> in <b>ON</b> position</li> <li>19. set the <b>DIP A10</b> in <b>ON</b> position, the <b>Led OK</b> make a flash.</li> <li>10. set the dips <b>B10</b> and <b>A10</b> in <b>OFF</b> position</li> </ol>	
<p><b>Erasing stop code</b></p> <ol style="list-style-type: none"> <li>11. open the contact on terminals n <b>13-14</b>.</li> <li>12. set the dip <b>A10</b> in <b>ON</b> position, the <b>Led OK</b> make a flash.</li> <li>13. close the contact on terminals n <b>13-14</b>.</li> </ol>	

### Erasing just one code.

- set the **DIP A10**.in **ON** position
- send a code already in memory, this code will be erasing the **Led OK** make a flash.
- set the **DIP A10**.in **OFF** position

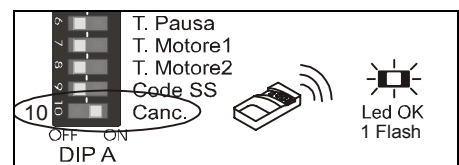

## <L> PRE-FLASHING DIP A1

- Set and leave the **DIP A1** in **ON** position, the pre-flashing is 3 seconds.

## <M> 45° WALK-WAY DIP A2

- set and leave the **DIP A2** in **ON** position.

## <N> NO ELECTRIC-LOCK COMMAND DIP B1

-- set and leave the **DIP B1** in **ON** position

## <O> NO DELAY IN CLOSING DIP B3

- set and leave the **DIP B3** in **ON** position, in this way booth gates close at the same time

## <P> LOCKING FOR WIND + SECURE LOCK DIP B5

Note : this function can be activated only if the dip B1 is in OFF position

-- set and leave the **DIP B5** in **ON** position

- When activated the motors make a short movement in closing before start to open, in this way is more easy to unlock the electric-lock even with bad wind condition
- !!! Pay attention on program motor n 2 in closing phase, after 3 seconds that the impulse for slowing down has been given the motor n 2 automatically will start at max force to thrust and close the electric-lock

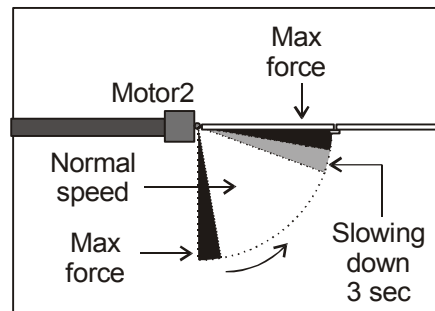

## <Q> OPEN GATE SIGNAL DIP B6

-- set and leave the **DIP B6** in **ON** position, on terminals n 24-25 you have a closing contact until the gate is opening.

## <R> COURTESY LAMP CONTACT TIME = 2 SECONDS DIP B7

-- set and leave the **DIP B7** in **ON** position , this may be useful if you want to command a lamp on a network

## <S> MOTOR SOFT START WHEN THE GATE IS NEAR THE PHYSICAL STOP DIP B9

- note the dip B4 must be OFF
- set and leave the **DIP B9** in **ON** position, in this way the start up is eliminate ( 1,5 sec max force and the gate does not make vibration when touch the physical stop
- it is important to set the trimmer FRENO for the right speed

## <T> INTERCOM INPUT

It is possible to feed 12vac on terminals n 3-4 , this give a command start SS or SS2 depend of the jumper setting

If jumper **CAR** is insert **Start/Stop**.command will be execute

If jumper **PED** is insert **WALK-WAY SS2** command will be execute

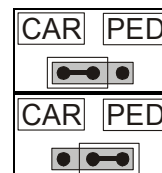

**BOX 208 IP56 SIZE mm**

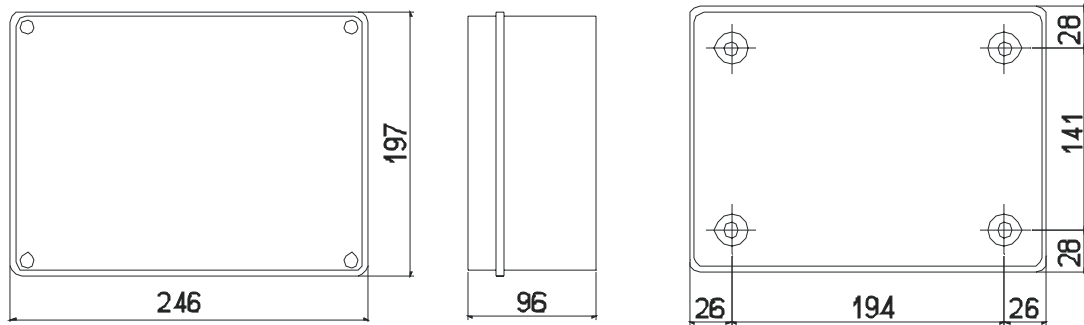

**WARRANTY**

ELCA devices and accessories are guaranteed for a period of 24 months after production, whose date is printed on each items. ELCA will replace or repair its devices, provided that they are returned to our plant. In order to check the actual functioning of the returned pieces, they will remain the property of manufacturer. The warranty does not include damages due to any incorrect use, such as : non fulfilment of the instructions detailed for each device. Moreover, warranty does not cover damage due to wrong tension supply and any other reason for wich the manufacturer cannot be made responsible. Any device returned must be delivered to ELCA with carriage paid and will be sent back with freight collect.

Warranty validity ceases in case of the customer's non fulfilment of payment.

ELCA declines all responsibility for the non observance of the safety rules by part of the installer.